

50/70T DZR

50 & 70 Tonne Mine Dozer

Technical Specifications Guide

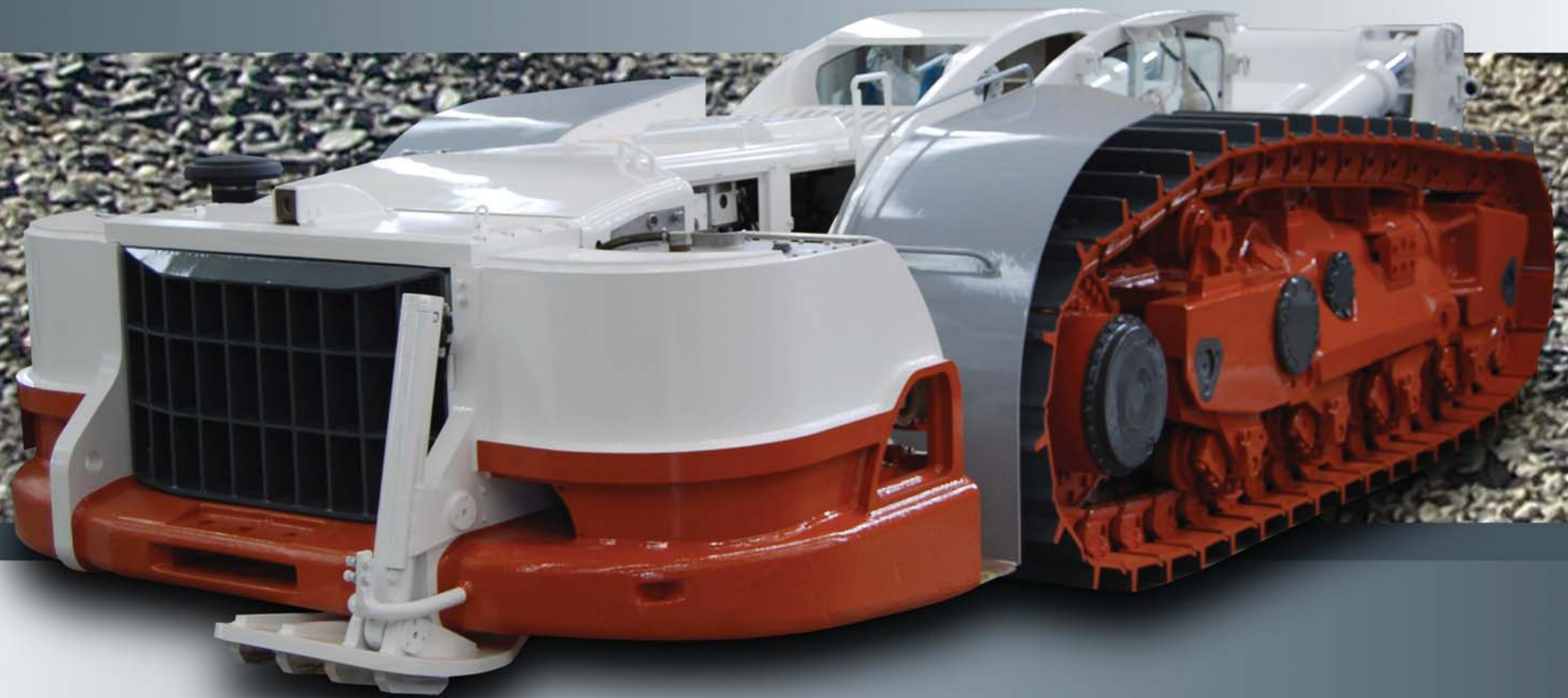

Vehicles that show their best advantage when mine conditions are most difficult.



50/70T DZR

50 & 70 Tonne Mine Dozer

The Industrea Mining Equipment Dozer can take control of heavy tasks in your mine; operate safely without exceeding design capacity. The new Industrea Mining Equipment Dozers feature industry leading Human Factor design, super draw bar pull and strong lift capacity.

Basic Features

1. 70 tonne rated forks
2. Fork locking mechanism
3. Winch system
4. Electrical System (8 flameproof headlights)
5. Fuel Tank
6. Water tank
7. Entry/Exit step
8. Diesel Engine System
9. Hydraulic control system
10. Rotating drivers seat
11. Drive direction controls
12. Implement latch, cabin height & winch controls
13. Dash gauges
14. Emergency stop button
15. Jib controls
16. Fork Controls
17. LCD Camera Display

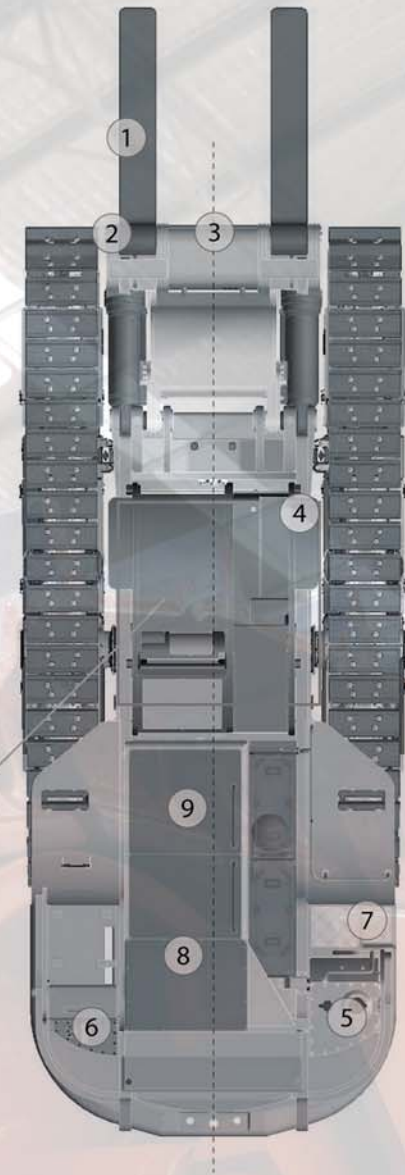

Purpose **built** for extreme conditions

Specifications

Specifications	50 T	70 T
Overall Length	9571 mm	11082 mm
Overall Width	3254 mm	3800 mm
Overall Height	1940/2240 mm	2120/2400 mm
Ground Clearance	262 mm	368 mm
Installed Power	242 kW diesel 200 kW Electric	242 kW diesel 200 kW Electric
Tare Weight	65 T	95 T
Draw Bar Pull	84 T	102 T
Travel speed	5.8 km/hr	5.5 km/hr
Winch capacity	25 T	35 T

Fork Implement

Lift capacity rating	50 T @ 1 m	70 T @ 1 m
----------------------	------------	------------

Jib Implement

Slew capacity rating	36 T	53 T (centre)
Lift capacity rating	25 T	44 T
Extension stroke	1200 mm	1200 mm

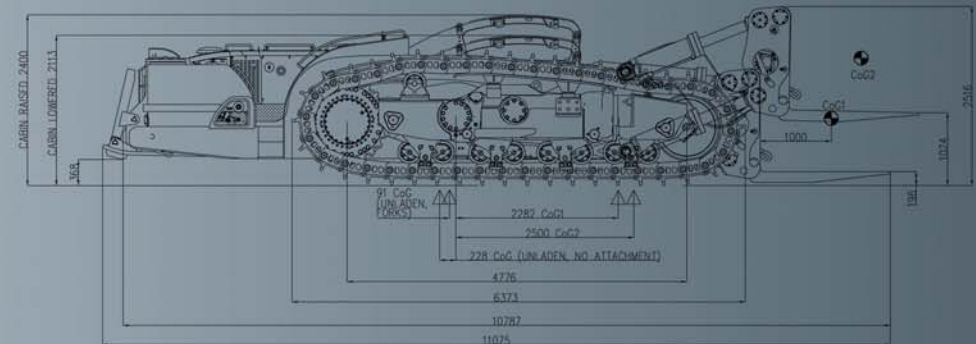
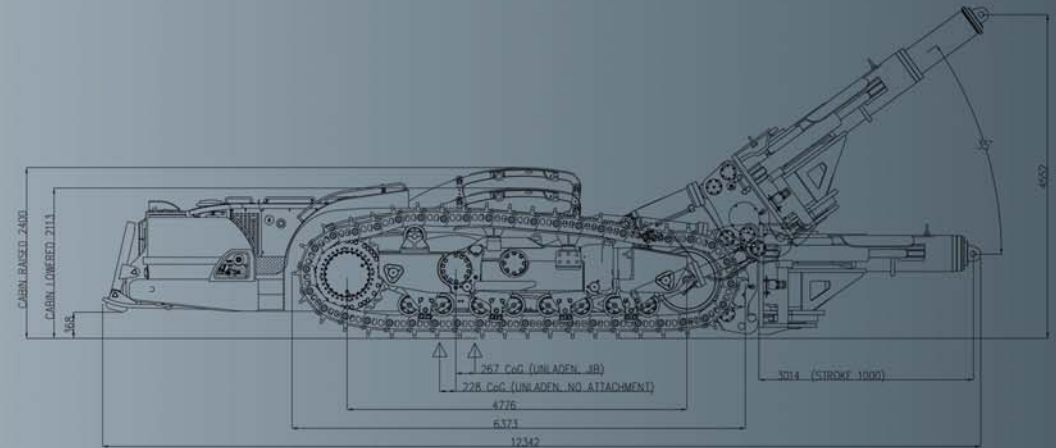

Vehicles that show their best advantage when mine conditions are most difficult.

www.industrea.com.au



Industrea Mining Equipment

63 Bonville Avenue
Thornton, New South Wales
Australia, 2322

t +61 2 4014 8500

f +61 2 4014 8599

w www.industrea.com.au